

Ref. 023451 - 400 V - 3φ  
Ref. 023499 (Pack)

Designed for the assembly of mild steel sheets with high elasticity. The GYSPOT INVERTER BP.LG is the ideal Spot Welder to meet Car Manufacturers requirements (550 daN / 13 000 A). Easy to handle and Reduced weight (6 kg), the new **GENIUS** clamp allows an automatic retraction of the electrodes in order for quick access of the welding area. The auto-mode allows welding without the operative entering any parameters into the machine. (mode AUTO).



## GENIUS INNOVATION

- **80 mm of automatic opening capacity** (20 mm at rest)
- Easy rotation of the arm in order to access hard to reach areas (200 mm of release).
- Clamp support and brass sole-arms for an optimal electrical contact.
- Modular concept of contacts in order to facilitate maintenance.
- **Quick arm removal without use of tools** thanks to double action feature.
- Automatic cooling connection.
- Remote controlled clamp (opening, welding, adjustments validation).
- **Lockable Gyroscope**, ball bearing, integrated into the clamp body.
- Handle, lever and reversible clamp support (right or left).
- Clear labelling ensures Quick identification of each arm (G1, G2, etc).
- Multifunction gun : single-point, swaging , studs, bolts, washers,...

## INTELLIGENT WELDING

- **AUTO mode** : the machine automatically recognizes - steel type, sheet-metal thickness, Panel bond presence and insulating material between HLE/THLE/ UHLE/Bore sheet-metal.
- 7 modes available : Normal, Manual, Multi, Gysteel, Auto, Manufacturer and Energy.
- **Tracking** : Recording Feature saves the characteristics of each welding spot performed to the SD card provided
- Easy transfer of saved reports to PC.

## HIGH PERFORMANCE

- Welding current : 13 000 A
- Clamping force : 550 daN at 8 bar.
- Watercooled power cables, electrodes and caps.
- Maximised productivity thanks to the new G clamp ram concept and the welding algorithm.
- User friendly navigation using a 5.7" LCD screen.
- Automatic adjustment of pressure between electrodes
- Spot count feature to determine the caps lifetime.
- Special welding of bonded sheet metals or hard to weld coatings.

## BODY PROTECTION

- Protected against overvoltage and overcurrent.
- Sound signal for pressure drop or low current.
- BODYPROTECT Technology to protect the user of magnetic fields (conforms to standard 2013/35/UE).

## ROBUST AND MOBILE

- Reinforced trolley which increases stability and monouverability with a 30L tank
- Highly resistant and double size stem (with or without extension).
- Support across the full length of the overhanging arm
- 6 arm support integrated.





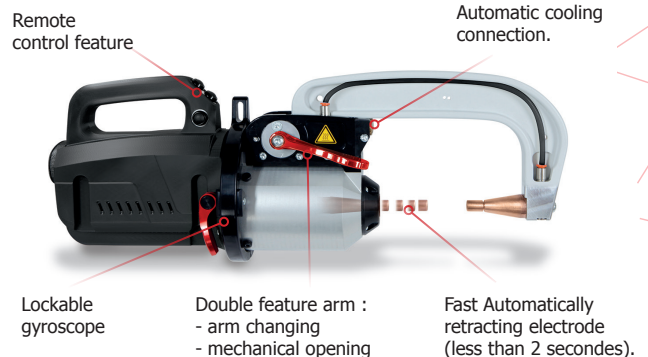





Included :  
- G1 arm  
- gun  
- earth cable  
- brackets  
- overhanging arm  
- ...  
(see next page)

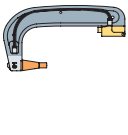
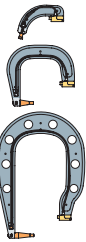

50/60Hz	A	I RMS A	U <sub>0</sub> V	P <sub>50%</sub> X=50% 32 kVA	mm		Cables (100% Cu)		cm	kg	IP	
					3+3+3	1.5+3	2.5m, Ø200mm <sup>2</sup> , Liquid	2.5m, Ø150mm <sup>2</sup> , Air				
400 V - 3φ	32 (D)	13 000	15.5	32 kVA	3 + 3 + 3	1.5 + 3	2.5 m, Ø200 mm <sup>2</sup> , Liquid	2.5 m, Ø150 mm <sup>2</sup> , Air	8 m 4x6 H07RNF	65 x 80 x 205	160	IP 20

## SUPPLIED WITH :

									
	B.P.L.G	Monopoint electrode	Consumables box	Inertia hammer	Cap remover	Arm support	G1	G2 + G3 + G4	Cooling liquid
ref. 023451	✓	✓	✓	✓	✓	✓	✓		
ref. 023499	✓	✓	✓	✓	✓	✓	✓	✓	✓ x3

## ISOLATED ARMS (OPTIONS)

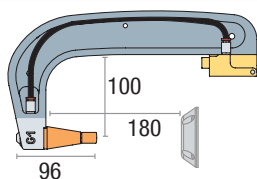

**G1 - 550 daN** ref. 022768

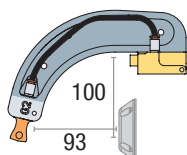

**G2 - 300 daN** ref. 022775

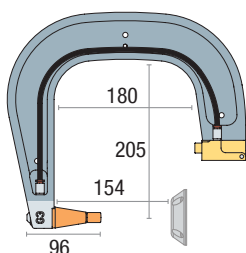

**G3 - 550 daN** ref. 022782

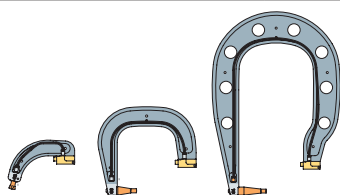

**G2 + G3 + G4** ref. 022898

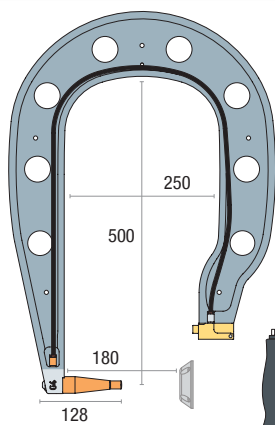

**G4 - 550 daN** ref. 022799

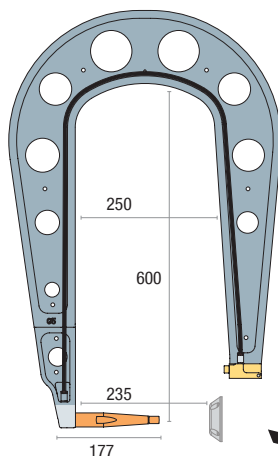

**G5 - 550 daN** ref. 022805

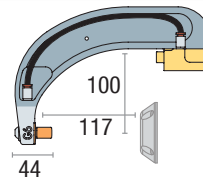

**G6 - 550 daN** ref. 022812

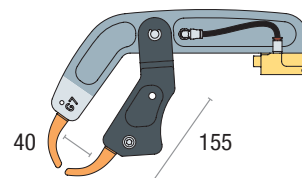

**G7 - 150 daN** ref. 022829

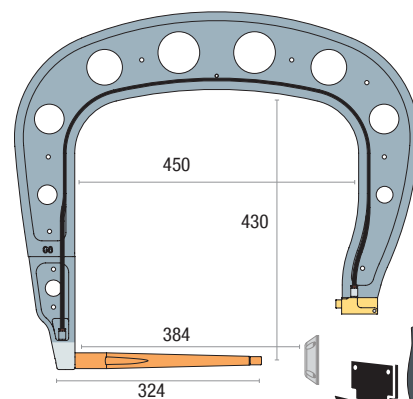

**G8 - 550 daN** ref. 022836