

CARTAR 
mobile hoist technology

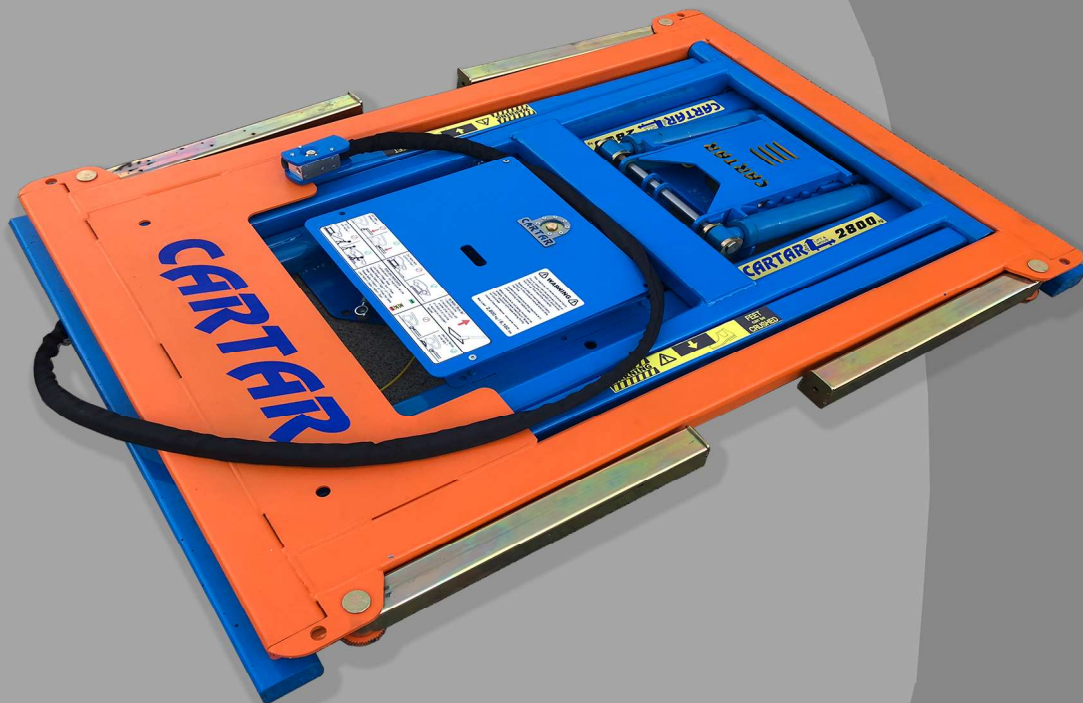

CARTAR Econo 100

*the new generation in “work-bay” Lifts
australian made - australian quality*



Benefits:

- 1/ Ground "Drive over" height of 100 mm.**
- 2/ Australian made - Australian Quality .**
- 3/ Air / Hyd Power system - Use inside or outside.**
- 4/ Comes standard with the Cartar SUV kit**
- 5/ No installation Costs - Ready to go on delivery .**
- 6/ Totally Compact with no Auxillary Oil Tanks and hoses**
- 7/ All Sealed Bearings with NO grease points.**



30 mm



160 mm

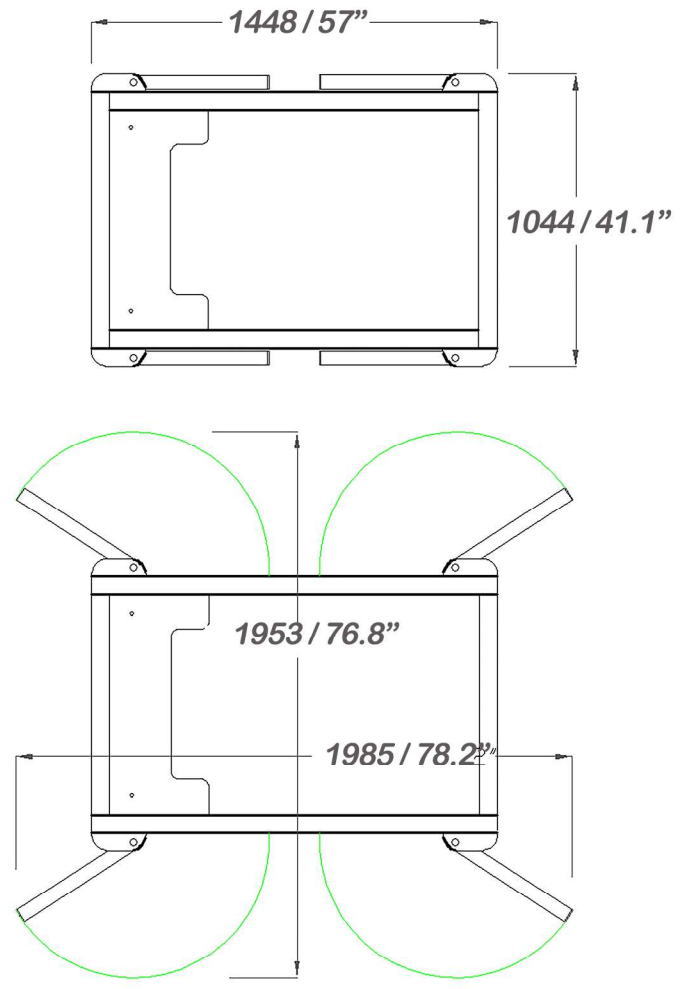
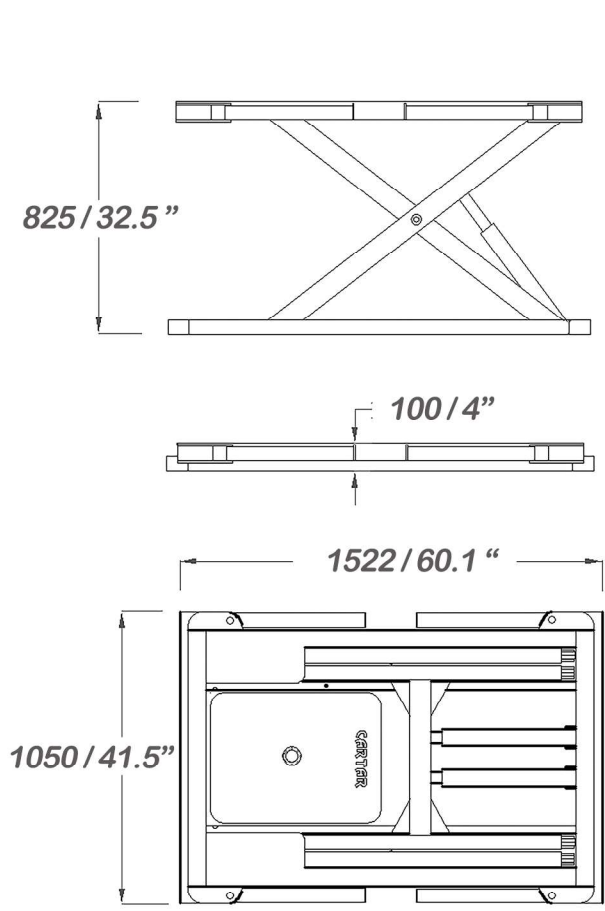

Technical Specifications

"Drive On " Ground Height	100 mm / 4 "
Elevated Height	820 mm/ 32.5"
Maximum Weight	2800 kg / 6210 lbs
Power Source	Compressed Air
Shipping Weight	265 kg / 584 lbs
Required Air Pressure	90 psi / 6.2 Bar
Average Air Consumption	13 cfm / 6.2 lpm
Air Consumption under Load	26.7 cfm / 12.6 lpm
Country of Manufacture	Australia
Power Pac	On Board
Factory Warranty	2 years Conditional
Weather Resistant	Inside or Outside
On Board Electrics	NIL