



Premium

VW AG | VAS 882 005



Labor saving



Advice & Service



Local support



NEW

ASE 882 005 80 000

Made in Germany

Metal Edge Cutter



VW AG | VAS 882 005

Premium



wheel arches

roof panels

- for the process-safe and precise removal of car body outer skin
- for cutting laser welding seams, beaded edges, surfaces and contours
- suitable for steel, ultra high strength steels and aluminium
- variable milling depths adjustable
- no damage to the deeper lying sheet metal structure
- variable angle positions guarantee universal applications
- innovative carbide special cutters
- high application security
- no flying sparks - in connection with the use of cutting oil
- no heat pre-treatment of the bodywork necessary
- rapid tool change

* LSN = Laser welding seams
**when used with a high performance cutting oil

roof panels

The **ALL-IN-ONE** tool for a reliable separation of the outer skin!

c-pillars

sills

wheel arches

door areas

sills / rocker panels

pillars

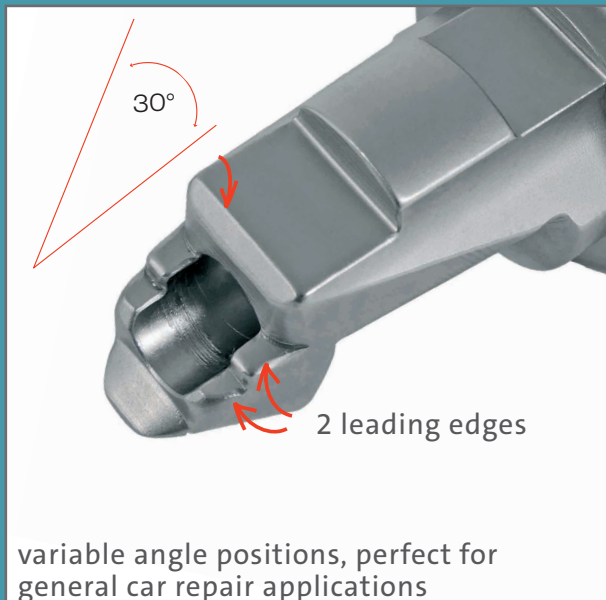



tech. data

air pressure:	6,3 bar max.
power:	600W
speed:	20.000 rpm
noise:	77dB(A)
vibration:	3.6m/s ²
hose length:	3100 mm
weight:	2,05 kg

item supplied:

- 1 x basic unit pneum. cpl.
 - 1 x machine attachment MEC
 - 1 x locking nut MEC600
 - 1 x flat head cutter Long Life
 - 1 x round head cutter LSN
 - 1 x aluminium cutter
 - 1 x setting gauge MEC600
 - 1 x protective cap
 - 1 x allen key
 - 1 x instruction manual incl. USB stick
- ASE 882 005 80 000

depth adjustment gauge
for an optimum milling depth

metal sheet thickness 0,6-1,5 mm



item N° 640052



milling cutter *Long Life*

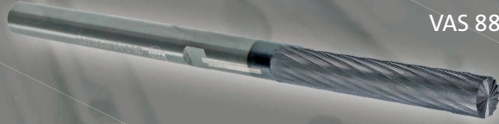

VAS 882 005/1

cutter tip with innovative cutting geometry

Ø 6 x 95 mm
ASE 882 006 80 A00 (932248)



milling cutter **ALU**



VAS 882 005/3

Ø 6 x 95 mm
ASE 882 006 80 C00 (932250)

milling cutter for laser welding seams



VAS 882 005/2

Ø 6 x 95 mm
ASE 882 006 80 B00 (932249)

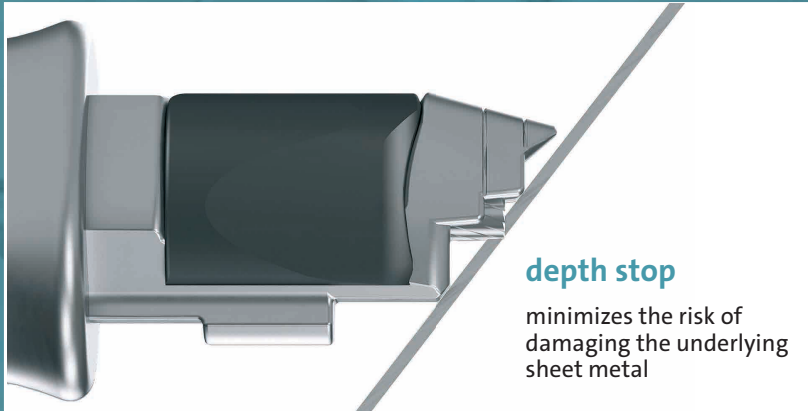

depth stop

minimizes the risk of damaging the underlying sheet metal



BTR-Fluid Cutting oil 125 ml

item N° 628000



Drill WAX lubricant 65g for ALU-milling cutters

item N° 640067

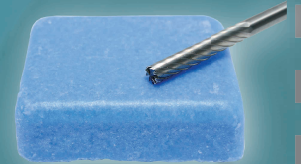

APPLICATION

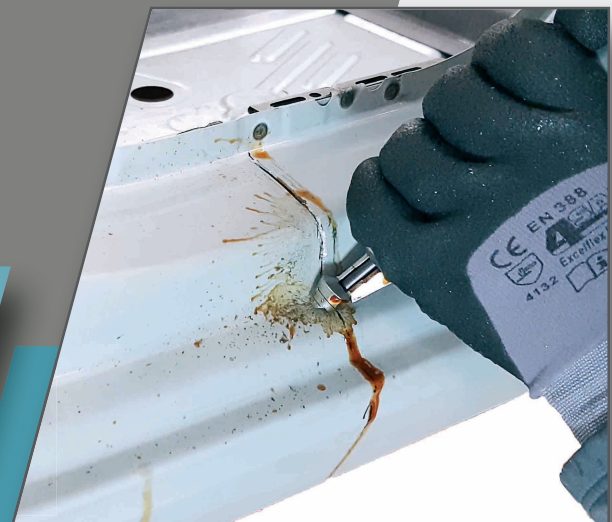

The metal edge cutter **VAS 882 005** has been developed as a reliable and precise way to separate the welded seams and removal of outer panels.





Wieländer+Schill[®]
Professionelle Karosserie-Spezialwerkzeuge