

The product of the continuous innovation and development by GYS, the **GYSPOT PTI GENIUS Plus** revolutionises spot welding technology. Fully automated and ultra-ergonomic, it is equipped with the most efficient overhanging arm on the market, with exceptional height, extended range, and improved swivel mechanism. It **offers unmatched mobility and accessibility**. The **patented cable locking system, unique to the market, allows for instant release and ultra-fast arm changeovers**. The clamp is the most lightweight on the market, and remains exceptionally ergonomic due to its pneumatic over-opening system and outstanding manoeuvrability. The **next-generation 7" colour interface** offers a clear display and intuitive navigation, optimising both set-up and day-to-day user experience.

ADJUSTABLE BALANCING SYSTEM

- **Motorised boom arm** to adjust height to accommodate vehicle dimensions.
- **Cable lock** for easy clamp release (GYS patent).
- Offset by **140 cm** of the power source for improved range.
- 90° folding boom arm to optimise space.
- Counterbalance to relieve the weight of the clamp, away from the working area.
- Rubber protectors on the ends of moveable parts.

HIGH PERFORMANCE

- **High duty cycle** with max. 14,500 A welding current, ideal for welding all types of steel on modern vehicles (HSS/VHSS, UHSS and Boron).
- **High speed** (15 spots/min).
- **Liquid-cooled** (30 litres) transformer, electrodes, and caps for maximum productivity.
- Clamping force up to **600 daN** at 8 bar to meet OEM requirements.
- **Clamp with integrated transformer**, reducing power consumption to a minimum (25 A fuse).

ERGONOMIC

- **Compact clamp** (12.4 kg) with 360° rotation via a built-in gyroscope.
- 6 m interconnection cable between clamp and machine for improved access to all areas of the vehicle. The interconnection cable can be disconnected for easier maintenance of the clamp.
- Reinforced, easy-to-manoeuvre trolley with 30-litre coolant tank.
- Integrated 9-arm support.
- Expander on the front wheels for greater stability.

EASY TO USE

- **Automatic mode:** the intelligent clamp detects the correct welding parameters automatically.
- **Pneumatic over-opening** for 80 mm clearance between the 2 caps.
- Improved user interface with **large 7" colour screen**.
- Easy to use for all automotive repair professionals.
- Spot counter to determine the service life of the caps.

PREMIUM G-ARMS

- **Instant and secure connection of G arms.**
- **Brass clamp holder** and arm foot plate for optimum electrical contact.
- **Automatic connection** of coolant terminals.
- Wide range of optional arms for full vehicle access.

OPTIMISED TRACEABILITY

- **Traceability** of spot welds, with data export via USB for reporting.
- Complete machine **updates** via USB stick.

OPTIONAL ACCESSORIES

- G PLUS BALANCING SYSTEM LIFT ([089105](#))
- Quick Fix single-point gun kit ([082823](#))
- [G arms and consumables](#)

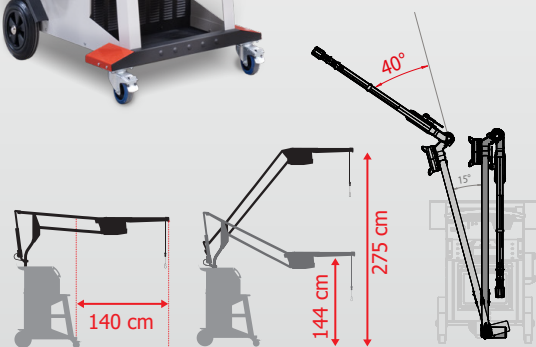

50/60Hz	A D-type	Spots / min (max.)	I _{RMS}	U ₀	S _{max}	S _p	mm		6 m, Liquid	Cables		Flüssig	cm	kg	
			A	V	kVA	kVA				(option)	(option)				
32 amp	25	15	14 500	7	92	16.5	2.5+2.5+2.5	1.5+3.0	6 m, Liquid	1.8 m	1 m	8 m	30 L	71 x 90 x 200	128